



# Butterfly Valves Type WBV



## Applications

- Powder and granule handling where a tight shut off is required
- Discharging powders from a silo or IBC
- Shut off and isolation
- Throttling conveying air
- Fume extraction systems

## Standard features

- Low break away torque allows smaller handles and actuators
- Reliable Kinetrol quarter turn pneumatic actuator
- Thin vane for minimal interference with product flow
- Infinitely variable vane position lock
- Tough cast iron, lightweight aluminium or stainless steel body
- Plated carbon steel or stainless steel vane and shafts
- Easily replaceable vane seal with valve in situ
- Body supplied with gasket O ring each side
- Standard O ring seal materials up to 200°C- Nitrile, Viton, EPDM etc

## Options

- Metal to metal seat
- High temperatures
- Spring return unit
- Bare shaft for your choice of actuator
- Position indicating switches

**For larger than standard sizes we custom manufacture to your requirements**

**Midland Industrial Designers Limited**

Common Lane • Watnall • Nottingham • England • NG16 1HD  
Fax: (+44)(0)115 9386315 • Tel: (+44)(0)115 9382154  
Manufacturers of powder handling equipment since 1962

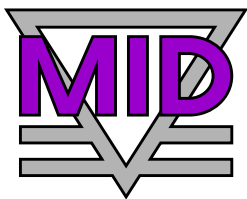

# Butterfly Valves Type WBV

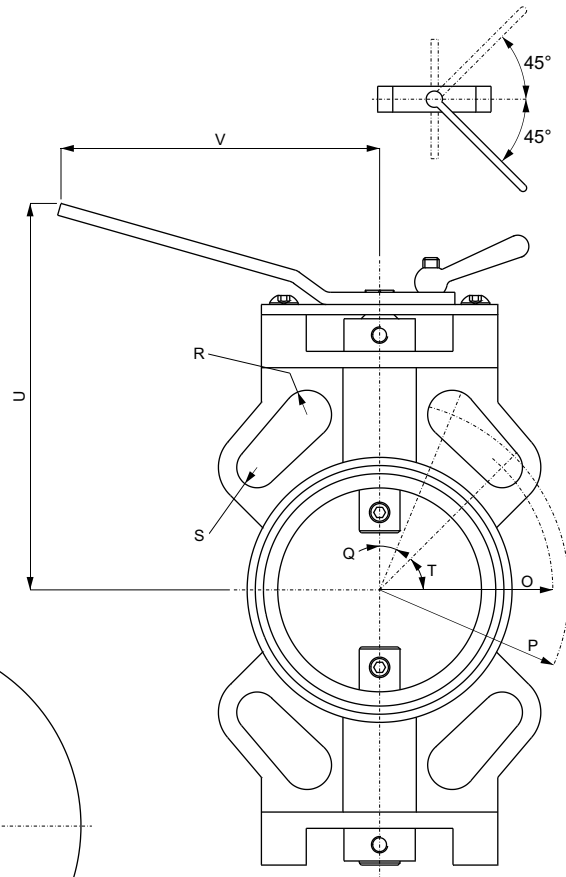
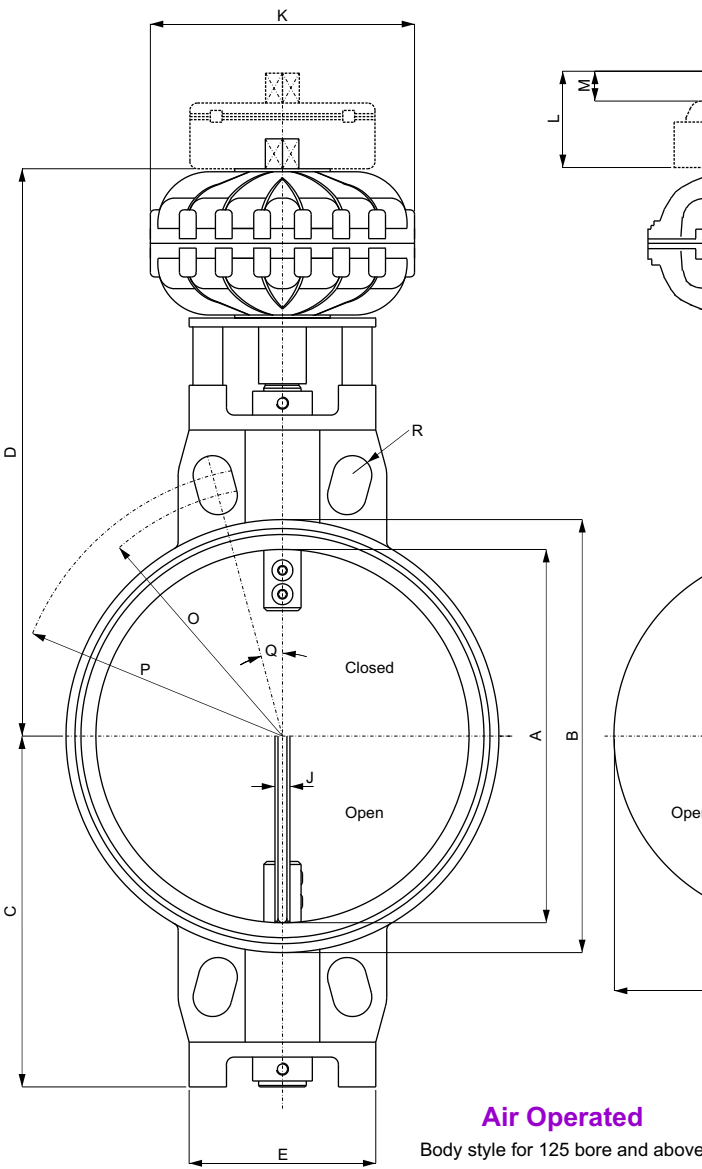

Size	BS4504 PN	BS 10 table	DIN 2501 PN	ANSI 150 sch
80	6 • 16	A • D • E	6 • 10	40
100	6 • 16	F	6 • 10	40
125	6 • 16	D • E	6 • 10 • 16	40
150	6 • 16	D • E	6 • 10	40
200	6 • 16	A • D • E	6 • 10	40
250	6 • 16	E	6 • 10	40
300	6 • 16	E	6 • 10	40
350	6	D • E	6	20
400	6 • 16	-	6 • 10 • 16	20
450	6	E	-	20
500	6 • 16	-	6 • 10 • 16	20

Flange Compatibility

Size	Actuator													Switches									
	A	B	C	D	E	F	G	H	J	K	L	M	N	M	N	O (rad)	P (rad)	Q°	R	S	T°	U	V
80	80	110	121	207	116	34	40	44	6	113	62	12	9	10	8	75	80	22.5	10	10	45	190	180
100	100	130	135	233	116	36	50	48	8	136	64	13	9.5	20	16	85	93	22.5	12	10	45	205	180
125	125	155	148	246	116	38	62.5	50	8	136	64	13	9.5	20	16	100	108	22.5	11	-	-	218	180
150	150	180	160	258	116	46	75	52	8	136	64	13	9.5	20	16	112	121	22.5	11	-	-	230	180
200	200	240	190	335	125	58	100	60	10	178	64	20	16	20	16	140	150	22.5	11	-	-	280	285
250	250	290	235	406	125	64	125	68	10	178	64	20	16	20	16	167	181	15	13	-	-	325	285
300	300	350	270	452	160	70	150	76	12	227	64	26	19	20	16	197	216	15	14	-	-	390	365
350	338	388	295	477	160	70	175	76	12	227	64	26	19	20	16	222	240	15	15	-	-	415	365
400	390	440	337	556	178	70	200	86	12	294	80	31	25	25	25	247	270	33.75	15	-	-	477	450
450	442	492	380	599	222	88	225	100	12	294	80	31	25	25	25	275	292	33.75	16	-	-	520	450
500	488	538	410	629	222	88	250	120	12	294	80	31	25	25	25	300	325	45	17	-	-	550	450

**Midland Industrial Designers Limited**  
 Common Lane • Watnall • Nottingham • England • NG16 1HD  
 Fax: (+44)(0)115 9386315 • Tel: (+44)(0)115 9382154  
 Manufacturers of powder handling equipment since 1962